

AMBEX, INC.
1947 Drew Street in Clearwater, Florida 33765
Phone (727) 442-2727 / Fax (727) 449-1194

AMBEX 5 KILO COFFEE ROASTER INSTALLATION REQUIREMENTS

GAS:

- 1/2" gas line with 3/8" standard gas flare fitting
- Gas pressure not to exceed 1/2 PSI
- Burner is rated at 45,000 BTU

EXHAUST:

- 5" exhaust port for roaster drum and 4" exhaust port for cooler (**type of ducting to conform with local code requirements, manufacturer recommends positive pressure; or Nordfab QF galvanized steel ducting**)

Wall thickness of ducting should be 20-22 gage minimum thickness.

- Exhausts can be vented separately or connected via a "Y" type fitting into an 7" or larger duct

**DO NOT USE TYPE "B" VENT MATERIAL **DO NOT CONNECT EXHAUSTS VIA A "T" TYPE FITTING **DO NOT USE THIS MACHINERY TOGETHER WITH A VENTED HOOD

- Both exhausts contain internal fans
- Exhaust temp. ambient-350 degrees F, 320 cfm, cooler exhaust 140 cfm, less than 280 degrees F for less than 2 minutes
- Cooler exhaust contains fresh air only

ELECTRICAL:

- (1) dedicated 15 A 110 VAC circuit
- Wall or floor mounted outlet as applicable

Equipment Classification:

All components used in the manufacture of the roaster unit; electrical and gas, are UL or CSA listed components. Component manufacture, model number and list numbers are available upon request.

CLEARANCES

- Install with minimum clearances as follows: these clearances are for ease of operation and are not required for safety

Rear - 24"

Right - 24"

Left - 12" exhaust side, distance between wall and exhaust pipe

Front - 36"

AMBEX, INC.
1947 Drew Street in Clearwater, Florida 33765
Phone (727) 442-2727 / Fax (727) 449-1194

Reference Picture below...

Picture A: Clearances

Picture B: Common Duct Layout

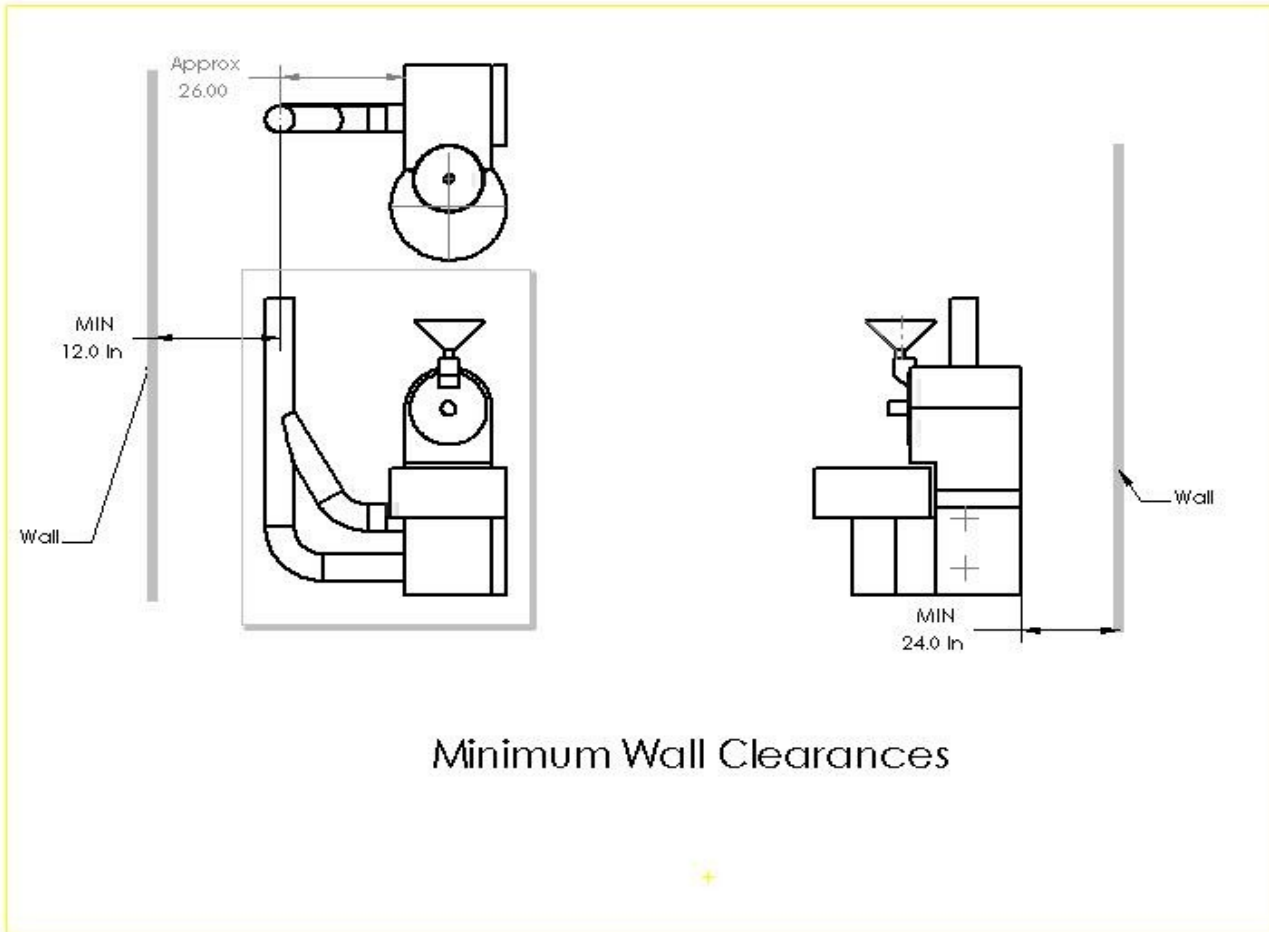

FLOORING:

- Floor must be able to handle the weight of the roaster (approx. 350 pounds), plus the weight of the operator and green coffee within an approximately 24 square foot area.
- It may be necessary to install sheet metal flashing, non-flammable tile, or fire bricks beneath roaster to conform with local fire and or building codes if flooring is hard wood or other flammable material.
- Ensure that roaster is level.

DIMENSIONS:

L- 44", W- 22", H-56"

