

AMBEX, INC.
1947 Drew Street in Clearwater, Florida 33765
Phone (727) 442-2727 / Fax (727) 449-1194

AMBEX 15 KILO COFFEE ROASTER INSTALLATION REQUIREMENTS

GAS:

- 1/2" gas line with 3/8" standard gas flare fitting
- Gas pressure not to exceed 1/2 PSI
- Burner is rated at 70,000 BTU

EXHAUST:

- 6" exhaust flue (**type of ducting to conform with local code requirements, manufacturer recommends positive pressure; or Nordfab QF, solid fuel ducting**)
- For units with additional cooler exhaust, single walled galvanized ducting will suffice, this exhaust contains no flue gases
- Exhausts can be vented separately or connected via a "Y" type fitting into an 9" or larger duct

**DO NOT CONNECT EXHAUSTS VIA A "T" TYPE FITTING **DO NOT USE TYPE "B" VENT MATERIAL **DO NOT USE THIS MACHINERY TOGETHER WITH A VENTED HOOD

- Both exhausts contain internal fans
- Exhaust temp. ambient-350 degrees F, 340 cfm, cooler exhaust 180 cfm, less than 280 degrees F for less than 2 minutes
- Cooler exhaust contains fresh air only

ELECTRICAL:

- (1) dedicated 15A 110 VAC or 6A 230 VAC circuit
- Wall or floor mounted outlet as applicable

CLEARANCES

- Install with minimum clearances as follows: these clearances are for ease of operation and are not required for safety

Rear - 24"
Right - 24"
Left - 12" exhaust side, distance between wall and exhaust pipe
Front - 36"

Reference picture below...

Picture A: Clearances

Picture B: Common Duct Layout

AMBEX, INC.
1947 Drew Street in Clearwater, Florida 33765
Phone (727) 442-2727 / Fax (727) 449-1194

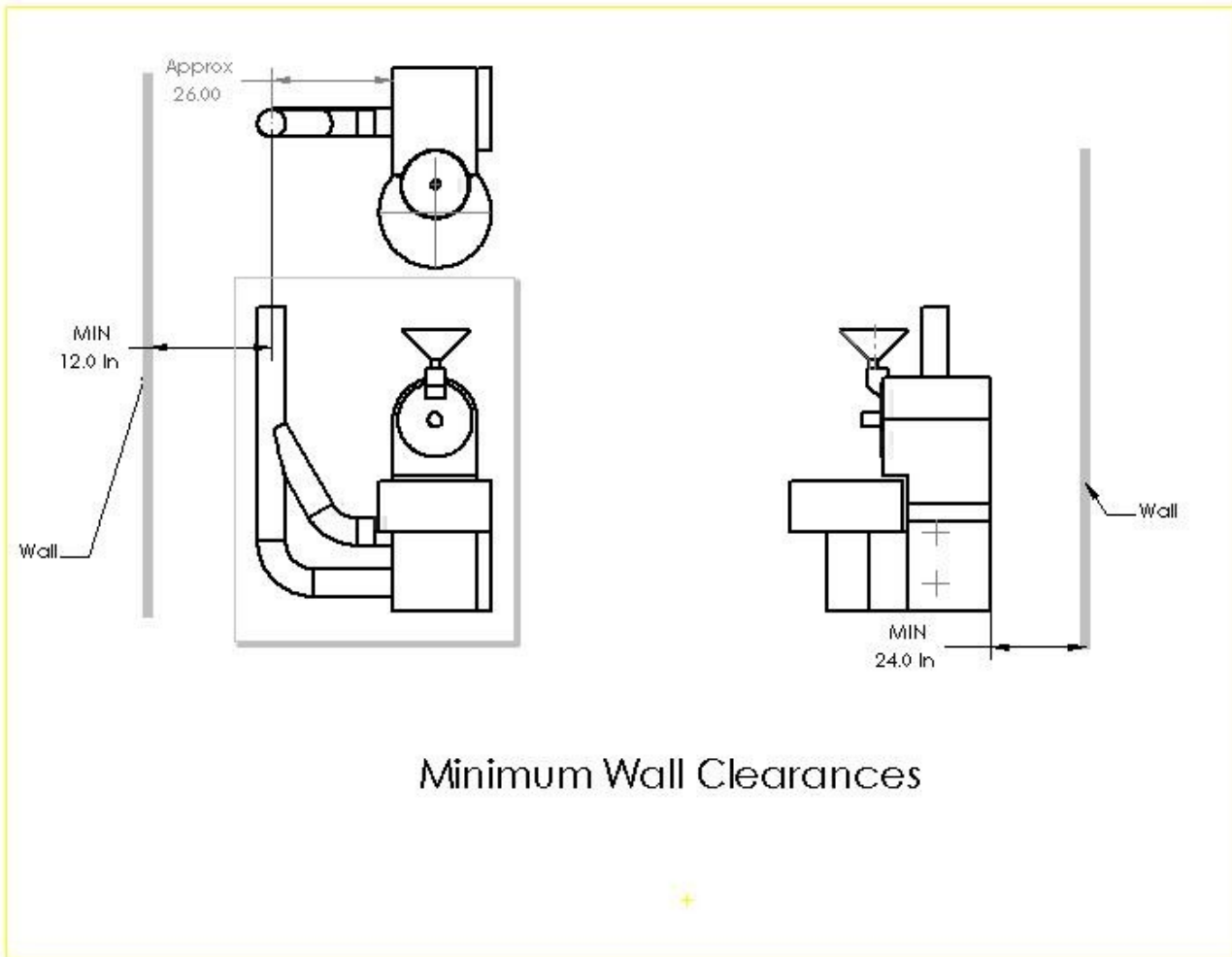

FLOORING:

- Floor must be able to handle the weight of the roaster (approx. 800 pounds), plus the weight of the operator and green coffee within an approximately 24 square foot area
- It may be necessary to install sheet metal flashing, non-flammable tile, or fire bricks beneath roaster to conform with local fire and or building codes if flooring is hard wood or other flammable material
- Ensure that roaster is level

DIMENSIONS:

L - 57" / W - 27" / H - 70"

AMBEX, INC.
 1947 Drew Street in Clearwater, Florida 33765
 Phone (727) 442-2727 / Fax (727) 449-1194

